

Mathematical Modeling of the Temperature Regime of the "Livestock-Heliogreenhouse Complex" with Water Tank and Underground Heat Accumulator

Sh. H. Ergashev¹, D. J. Nurmatova²

¹*Karshi Engineering Economic Institute, Karshi, Uzbekistan*

²*Karshi State University, Karshi, Uzbekistan*

ABSTRACT

The article develops a mathematical model of the heat supply system of the greenhouse complex, taking into account the free heat flow in the animals, solar energy, heat energy stored in heat accumulators and developed through the program MATLAB / Simulink. In the development of a mathematical model of the heat supply system of the greenhouse complex, a block diagram of the equation in the program MATLAB / Simulink was developed, without taking into account the change in air density and specific heat capacity with temperature. According to the graphic results obtained for the daily value of solar radiation 500 W/m^2 , outside air temperature, $-6 \text{ }^\circ\text{C}$ in Karshi, the air temperature inside the greenhouse rises to $22 \text{ }^\circ\text{C}$, water tank battery temperature to $13 \text{ }^\circ\text{C}$, underground heat accumulator temperature to $17 \text{ }^\circ\text{C}$. can be seen. while the amount of total solar radiation was 300 W/m^2 , this figure was found to be $14 \text{ }^\circ\text{C}$, $9 \text{ }^\circ\text{C}$, and $12 \text{ }^\circ\text{C}$.

1. Introduction

The strategic directions of energy development in the Republic of Uzbekistan provide for the widespread use of non-traditional energy sources, including the energy of organic animal biomass. Calculations show that when processing organic biomass into biological gas, 4.2 times more energy can be produced annually than is produced at power plants in the Republic of Uzbekistan. Closely related to the problem of waste management is another - increasingly exacerbating - environmental protection, which also requires intensive and rational processing of organic biomass.

The use of renewable energy in the world is becoming increasingly important because traditional sources of energy (coal, oil, natural gas) are limited, and their use for the production of heat and electricity causes great harm to the environment. In this regard, solar energy is becoming increasingly important, which can be used to produce environmentally friendly heat and electric energy [1,2,3,4].

The sun is a giant source of "clean" energy, not polluting the environment. Efficient use of solar energy can significantly reduce the consumption of natural resources. Climatic and weather conditions in the south of Uzbekistan create wide opportunities for the efficient use of solar energy in the Kashkardarya region [2,3,4,5].

To achieve maximum efficiency of biogas formation, anaerobic processing requires certain temperature conditions and technological processes, preferably close to achieving the optimum process [6,7].

The current stage of agricultural construction is characterized by a tendency to expand the greenhouse economy and mobilize everyone, including technical means to increase the productivity of greenhouses. This trend is aimed at solving the problem of providing the population with fresh vegetables in the required quantities throughout the year and, which is especially important in the cold period from October to May [7,8].

<https://cejsr.academicjournal.io>

Until now, the cultivation of crops and plants in greenhouses with technical heating has been recognized, the costs of which amount to 55-60% of the total costs. This imposes a special responsibility on the choice of design of the heating system for greenhouses [1,3,4,5].

Construction of a heating system for the airspace and the root layer of the soil of greenhouses, high costs of materials and funds for construction and installation work, annual fuel use, limiting the thickness of the root layer by placing heating structures in it, the presence of zones of local overheating of the soil, the cost of maintaining the system significantly affect for the cost of products grown in the greenhouse [1,2].

2. Materials and methods.

Lowering temperatures in greenhouses against the required ones entails a decrease in yield and death of plants and vegetables. A decrease in humidity leads to a sharp decrease in the yield of vegetables and a loss of their marketability. Excessive moisture leads to the production of watery high-quality vegetables and, as a rule, leads to the development of their diseases [6,7].

The most effective way to improve the construction of solar greenhouses is to combine mathematical modeling with field tests. The use of mathematical modeling of heat transfer processes makes it possible to analyze the effectiveness of the proposed design solutions under various external conditions much faster than in field studies. Therefore, the development of sufficiently flexible mathematical models of solar greenhouses is relevant, allowing one to take into account the geometric and physical features of structures.

The mathematical models of solar greenhouses described in the literature are characterized by insufficient flexibility due to the fact that they are designed for a certain geometry of the structure, or only part of the processes are taken into account in them. In addition, a typical feature of these models is the use of empirical coefficients, which can only be measured (or calculated from measurements) using field tests [1].

This paper proposes an approach to the construction of mathematical models of solar greenhouses based on the modern theory of heat and mass transfer.

Providing the required temperature and humidity conditions for soil and air in greenhouses is a serious task, which is complicated by the need to save heat energy and minimize water consumption for irrigation.

The research methodology was based on the methods of mathematical modeling and computational studies using a computer, instrumental studies of the physical characteristics of the greenhouse-livestock complex, the theory of similarity, and static processing of experimental data [8].

For an effective solution to the problem of soil and air moistening in solar greenhouses, it is advisable to fundamentally focus on an intra-soil irrigation system with preheating of water.

At present, in the development of farms and businesses in the country, special attention is paid to the modernization of livestock buildings based on modern systems, the introduction of energy-efficient, high-efficiency equipment, technologies, and modern equipment, in particular the use of renewable energy sources. is focused. For this purpose, an experimental version of the device consisting of a flat-walled water tank and an underground heat accumulator greenhouse-livestock complex designed to create a temperate climate regime using solar and bioenergy for family entrepreneurs was developed (Figure 1).

The livestock building is designed for 40 head of livestock, and the amount of harmful gases in the air of the livestock building is normalized, along with the partial heating of the greenhouse air by utilizing the free heat flow separated from the livestock. On sunny days, the solar energy that enters the greenhouse is stored underground and in a water tank located between the livestock building and

<https://cejsr.academicjournal.io>

the greenhouse. On chronic cloudy days, a microclimate is created in the greenhouse at the expense of gas from the biogas plant [9,10,11,12,13]. The mathematical model of the combined thermal greenhouse-livestock complex with the design of the thermal regime of constructive, technical, technological, and meteorological systems can be written as follows:

$$\begin{cases} \rho \cdot V_{liv.b.} \cdot c \frac{dt_{liv.b.}(\tau)}{d\tau} = Q_{liv.} - (Q_{bar.} + Q_{ven.} + Q_{steam} + Q_{inf.} + Q_{g.h.wall}); \\ \rho \cdot V_{g.h.} \cdot c \frac{dt_{g.h.}(\tau)}{d\tau} = Q_{ven.} + Q_{rad.} + Q_{\sigma.z.} - Q_{g.h.bar.} - Q_{g.h.wall} - Q_{ung.ac} - Q_{bak.ac}; \\ \rho \cdot V_{ung.ac} \cdot c \frac{dt_{ung.ac.exit}(\tau)}{d\tau} = L_{ung.ac} \cdot \rho \cdot c (t_{g.h.}(\tau) - t_{ung.ac.exit}(\tau)) - \alpha_{ung.ac} \cdot F_{ung.ac} (0,5 \cdot (t_{g.h.}(\tau) + t_{ung.ac.exit}(\tau)) - t_{ung.}); \\ \rho \cdot V_{bak.ac} \cdot c \frac{dt_{bak.ac.exit}(\tau)}{d\tau} = L_{bak.ac} \cdot c \cdot \rho (t_{g.h.}(\tau) - t_{bak.ac.exit}(\tau)) - \alpha_{bak.ac} \cdot F_{bak.ac} (0,5 \cdot (t_{g.h.}(\tau) + t_{bak.ac.exit}(\tau)) - t_{bak.ac}(\tau)); \\ (m_w \cdot c_w + m_m \cdot c_m) \frac{dt_{bak.ac}(\tau)}{d\tau} = K_{bak.ac} \cdot F_{bak.ac} (0,5 \cdot (t_{g.h.}(\tau) + t_{bak.ac.exit}(\tau)) - t_{bak.ac}(\tau)); \end{cases} \quad (1)$$

where: $Q_{liv.} = n \cdot q_{liv.}$ - heat flux freely separated from livestock; in this, n - number of livestock, $q_{liv.}$ - heat flux from a single livestock, W; $Q_{bar.} = Q_{out.wall} + Q_{ceiling} + Q_{floor}$ - heat flux lost through the barrier (outer wall, ceiling and floor), W;

$Q_{out.wall} = \frac{F_{out.wall}}{R_{out.wall}} (t_{liv.b.}(\tau) - t_{ext.}) + \frac{F_{win}}{R_{win}} (t_{liv.b.}(\tau) - t_{ext.})$ - heat flux lost through the outer wall, W;

$Q_{ceiling} = \frac{F_{ceiling}}{R_{ceiling}} (t_{liv.b.}(\tau) - t_{ext.})$ - heat flux lost through the ceiling, W; $Q_{floor} = \frac{F_{floor}}{R_{floor}} (t_{liv.b.}(\tau) - t_{ext.})$ - heat loss

through the floor, W; $Q_{steam} = 0,278 \cdot 2,49 \cdot W_{steam}$ - Heat used to evaporate moisture (from floors, irrigation, nutrition, etc.) that evaporates from the damp surface of a building, W; $Q_{inf.} = 0,1 \cdot Q_{out.wall}$ - heat flux lost through infiltration, W; $Q_{ven.} = L_w \cdot \rho \cdot c \cdot (t_{liv.b.}(\tau) - t_{g.h.}(\tau))$ - heat exchange in the air

exchange between the livestock building and the solar house, W; $Q_{rad.} = \bar{q}_{fall} \cdot \kappa_{trans} \cdot \alpha_{trans} \cdot F_{g.h.}$ - solar radiation entering the greenhouse, W; $Q_{b.g.} = G_w \cdot c_w (t_{int.} - t_{exit})$ - heat transferred from a biogas boiler unit, W;

$Q_{g.h.bar.} = \kappa_{inf.} \cdot K \cdot F_{g.h.} (t_{g.h.}(\tau) - t_{ext.})$ - heat flux lost through greenhouse barriers, W ;

$Q_{ung.ac} = L_{ung.ac} \cdot \rho \cdot c (t_{g.h.}(\tau) - t_{ung.ac.exit}(\tau))$ - heat transferred to the underground heat accumulator, W;

$Q_{g.h.wall} = \frac{F_{g.h.wall}}{R_{out.wall}} (t_{liv.b.}(\tau) - t_{g.h.}(\tau))$ - heat loss through the wall between the livestock building and the

greenhouse, W; $Q_{bak.ac} = L_{bak.ac} \cdot c \cdot \rho (t_{g.h.}(\tau) - t_{ung.ac.exit}(\tau))$ - the water used to heat the water tank heat accumulator mounted on the wall between the livestock building and the greenhouse, W;

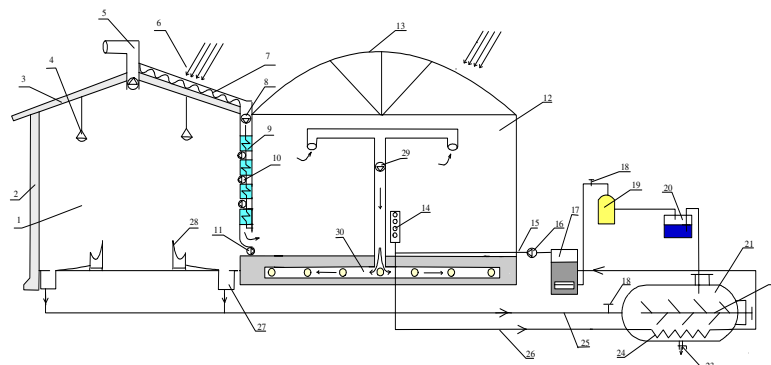

Fig.1. "Livestock-heliogreenhouse complex". 1-livestock building; 2-wall; 3-part of the roof; 4-lighting fixtures; 5-ventilation ducts; 6- sunlight; 7-solar air heating collector; 8-hot air supply fan in

<https://cejssr.academicjournal.io>

collector; 9-flat-wall heat accumulator with water tank; 10-solargreenhouse fan to drive indoor air into the livestock building; 11-livestock building air-driven fan; 12-solargreenhouse; 13-transparent coating of solargreenhouse; 14-heating battery of solar panels; 15-hot water supply pipeline; 16-hot water pump; 17-water heating boiler; 18-valve; 19-gas holder; 20-refrigerator; 21-bioreactor; 22-mixer; 23-biomass spill site; 24-circulating water pipeline; 25-manure transmission line; 26-hot water return pipe; 27-manure collectors; 28-pet feeder; 29-solargreenhouse fan that drives the indoor air to the underground heat accumulator;

30- underground heat accumulator.

(1) All the components of the equation can be expressed as follows:

$$\left\{ \begin{array}{l} \rho \cdot V_{liv.b.} \cdot c \frac{dt_{liv.b.}(\tau)}{d\tau} = n \cdot q_{liv.} - (1, l \left(\frac{F_{out.wall}}{R_{out.wall}} + \frac{F_{win}}{R_{win}} \right) + \frac{F_{ceiling}}{R_{ceiling}} + \frac{F_{floor}}{R_{floor}}) (t_{liv.b.}(\tau) - t_{ext.}) - \frac{F_{g.h.wall}}{R_{out.wall}} (t_{liv.b.}(\tau) - t_{g.h.}(\tau)) - \\ - L_w \cdot \rho \cdot c \cdot (t_{liv.b.}(\tau) - t_{g.h.}(\tau)) - 0,278 \cdot 2,49 \cdot W_{steam}; \\ \rho \cdot V_{g.h.} \cdot c \frac{dt_{g.h.}(\tau)}{d\tau} = L_w \cdot \rho \cdot c \cdot (t_{liv.b.}(\tau) - t_{g.h.}(\tau)) + q_{fall} \cdot \kappa_{trans} \cdot \alpha_{trans} \cdot F_{g.h.} + G_w \cdot c_w \cdot (t_{int.} - t_{ext.}) - \kappa_{inf.} \cdot K \cdot F_{g.h.} (t_{g.h.}(\tau) - t_{ext.}) - \\ - L_{ung.ac.} \cdot \rho \cdot c (t_{g.h.}(\tau) - t_{ung.ac.exit}(\tau)) - L_{bak.ac.} \cdot c \cdot \rho (t_{g.h.}(\tau) - t_{bak.ac.exit}(\tau)); \\ \rho \cdot V_{ung.ac.} \cdot c \frac{dt_{ung.ac.exit}(\tau)}{d\tau} = L_{ung.ac.} \cdot \rho \cdot c (t_{g.h.}(\tau) - t_{ung.ac.exit}(\tau)) - \alpha_{ung.ac.} \cdot F_{ung.ac.} (0,5 \cdot (t_{g.h.}(\tau) + t_{ung.ac.exit}(\tau)) - t_{ung.}); \\ \rho \cdot V_{bak.ac.} \cdot c \frac{dt_{bak.ac.exit}(\tau)}{d\tau} = L_{bak.ac.} \cdot c \cdot \rho (t_{g.h.}(\tau) - t_{bak.ac.exit}(\tau)) - \alpha_{bak.ac.} \cdot F_{bak.ac.} (0,5 \cdot (t_{g.h.}(\tau) + t_{bak.ac.exit}(\tau)) - t_{bak.ac.}(\tau)); \\ (m_w \cdot c_w + m_m \cdot c_m) \frac{dt_{bak.ac.}(\tau)}{d\tau} = K_{bak.ac.} \cdot F_{bak.ac.} (0,5 \cdot (t_{g.h.}(\tau) + t_{bak.ac.exit}(\tau)) - t_{bak.ac.}(\tau)); \end{array} \right. \quad (2)$$

Greenhouse-livestock complex includes the following technological processes. The 1 wall 2 and the roof 3 of the livestock building are made of heat-insulating materials. The building is equipped with energy-saving lighting fixtures 4. When the indoor air temperature of the livestock building rises, ventilation pipe 5 is activated and normalizes the indoor air temperature. Sunlight 6 A solar air heater 7 installed on the roof of a livestock building heats the air, the heat of the air being driven by the fan 8 is accumulated in a flat-walled heat accumulator 9. As the indoor air temperature rises above 24 °C, fan 10 sucks the air through a flat-walled heat accumulator and pumps it into the livestock building. As a result of the respiration of livestock inside the livestock building, carbon dioxide-saturated air is introduced into the greenhouse 12 through a fan 11, which improves the indoor microclimate and accelerates plant growth. In the daytime mode, the sunlight passing through the transparent coating 13 has its effect on the heating of the air in the greenhouse 12 and causes the temperature to rise to 24 °C. At night, when the internal temperature of the building drops below 15 °C, fan 10 stops working, and the air driven by fan 8 pushes the heat from the flat-walled heat accumulator into the solar panel. On cloudy days and in the evenings when the air temperature is low, the greenhouse is heated by hot water heating coils 14 supplied from the water heating boiler 17 using a pump 16 through a hot water supply pipe 15. In the water heating boiler, the biogas generated in the bioreactor 21 is burned to pass through valve 18, collected in the gas holder 19, and processed in the refrigerator 20 chilled manure. In the bioreactor, the manure mass is stirred during the fermentation process through a mixer 22, and after using the biomass, the residual fertilizer is removed through the discharge point 23 in the reactor.

The temperature in the bioreactor is regulated using water flowing through an inner tube 24.

27 manure is delivered from the manure collector using a transmission line 25 to the bioreactor. The hot water flowing out of the water heating boiler passes through the soil layer of the solar panel and the flow of hot water to the heating coils 14 is adjusted employing valves 18 depending on the climatic conditions. 26 water in the return pipe is directed to the heating boiler. In turn, on sunny days, as the internal temperature of the solar panel rises above 24 °C, hot air is pumped through the

<https://cejsr.academicjournal.io>

fan 29 to the underground heat accumulator 30 and excess heat is accumulated, helping to improve the microclimate conditions of the solar panel at night.

3. Results and discussion

(2) In the development of the mathematical model, we construct a block diagram (Figure 2) in the MATLAB/Simulink program, expressing all the magnitudes of the equation in Table 1, without taking into account the change in air density and specific heat capacity over temperature [14].

Table 1

No	Parameters	Assignment	Unit of measurement	Value
1	Density of air	ρ	kg/m ³	1,293
2	The size of the livestock building	$V_{liv.b.}$	m ³	720 m ³
3	The size of the greenhouse	$V_{g.h.}$	m ³	540 m ³
4	Specific heat capacity of air	c	J/(kg · °C)	1005
5	Number of livestock	n	-	40
6	Free heat released from a single animal	$q_{liv.}$	W	593
7	Thermal resistance of the outer wall	$R_{out.wall}$	(m ² · °C)/W	1,34
8	Exterior wall surface	$F_{out.wall}$	m ²	126
9	Outdoor air temperature	$t_{ext.}$	°C	-6°C
10	Thermal resistance of the exterior (door and window) window	R_{win}	(m ² · °C)/W	0,345
11	The surface of the windows	F_{win}	m ²	12
12	Thermal resistance of roofing	$R_{ceiling}$	(m ² · °C)/W	2,79
13	Roof and floor surface	$F_{ceiling} = F_{floor}$	m ²	240
14	Thermal resistance of the floor layer	R_{floor}	(m ² · °C)/W	4,46
15	Air exchange consumption in the livestock building	L_w	m ³ / s	2,772
16	Moisture that evaporates from the damp surface of the building (floors, from watering, feeding, etc.).	W_{steam}	g/hour	2550
17	Solar radiation falling on 1 m ² of surface	$q_{fall.}$	W/m ²	200-500
18	Coefficient	κ_{trans}	-	0,8
19	Coefficient	α_{trans}	-	0,8
20	Greenhouse surface	$F_{g.h.}$	m ²	180
21	Infiltration coefficient	$\kappa_{inf.}$	-	1,1-1,2
22	Heat transfer coefficient of two-layer polyethylene film	K	W/(m ² · °C)	5,8
23	The mass of water in the tank accumulator	m_w	kg	2880
24	Specific heat capacity of water	c_w	J/(kg · °C)	4180
25	The mass of the tank battery material (metal)	m_m	kg	834
26	Specific heat capacity of metal	c_m	J/(kg · °C)	460
27	Volumetric consumption of air pumped to the underground heat accumulator	$L_{ung.ac.}$	m ³ / s	0,1413

<https://cejsr.academicjournal.io>

28	Volumetric consumption of air pumped to the water tank accumulator	$L_{bak.ac}$	m^3 / s	0,35325
29	The of the underground heat accumulator	$V_{ung.ac}$	m^3	6,1544
30	The size of air between the water tank battery wall	$V_{bak.ac}$	m^3	9,6
31	Heat exchange surface of underground heat accumulator pipes	$F_{ung.ac}$	m^2	123
32	The heat exchange surface of the water tank accumulator	$F_{bak.ac}$	m^2	52,8
33	Coefficient of heat transfer of air to the underground heat accumulator	$\alpha_{ung.ac}$	$W / (m^2 \cdot ^0 C)$	0,75
34	The coefficient of heat transfer by air to the water tank accumulator	$\alpha_{bak.ac}$	$W / (m^2 \cdot ^0 C)$	25
35	The heat transfer coefficient between the water tank accumulator and the air	$K_{bak.ac}$	$W / (m^2 \cdot ^0 C)$	24,5
36	Mass consumption of hot water supplied from the biogas boiler to the heating batteries in the greenhouse	G_w	kg/s	0,5

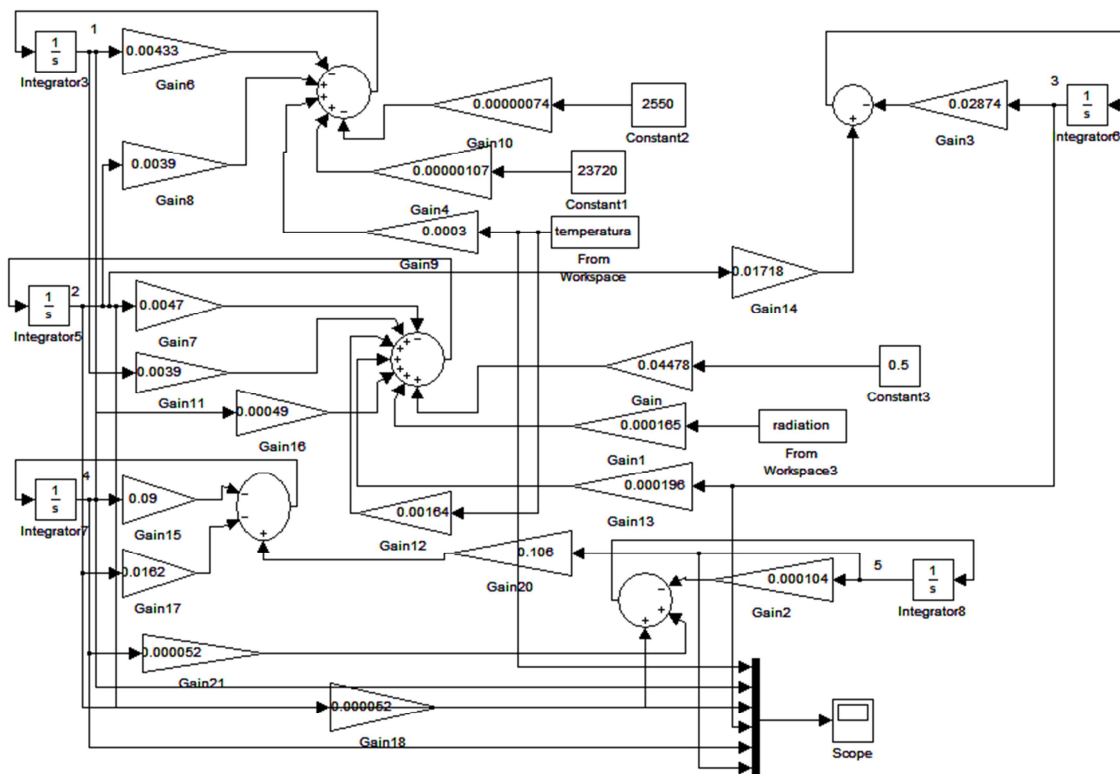

Fig.2. Block diagram of the mathematical model of the heat supply system of the greenhouse-livestock complex in the program MATLAB/Simulink.

Given that the daily value of solar radiation in the conditions of the city of Karshi is $\bar{q}_{fall} = 200 - 500 W / m^2$, the following results can be obtained from the block diagram in Figure 2 for the case of outdoor air temperature $-6^0 C$:

<https://cejssr.academicjournal.io>

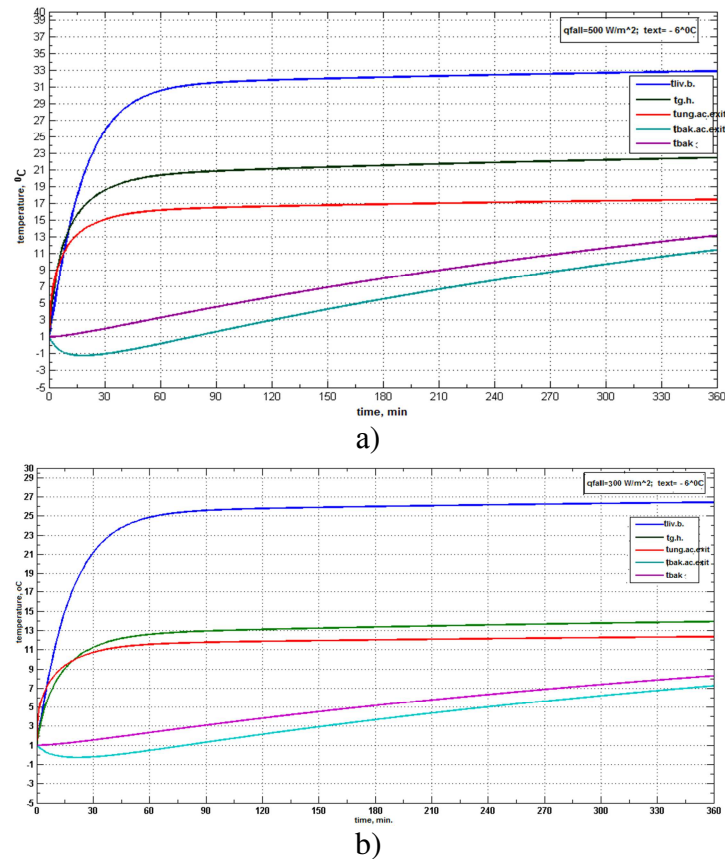

Fig.3. The graph shows the changes in the temperature of the livestock building, greenhouse, underground heat accumulator, and water tank accumulator.

As can be seen from the graphs of Figure 3, even though the outside air temperature is 6 °C, when the total solar radiation is 500 W/m², the indoor air temperature rises to 22 °C, the water tank battery temperature to 13 °C, and the underground heat accumulator temperature to 17 °C can be seen. while the amount of total solar radiation is 300 W/m², it can be seen that this figure will be 14 °C, 9 °C, and 12 °C.

By utilizing the free heat emanating from the cattle into the greenhouse in the livestock building, we can also meet the need for CO₂ gas in the plants. If the plant a by red and blue rays in a ratio of 1:4, the photosynthesis intensifies, its efficiency increases. The amount of CO₂ gas required for photosynthesis in atmospheric air is relatively short (0,03%). Photosynthesis begins when the amount of CO₂ in the atmosphere is 0,008%. With the increase in the amount of this gas, photosynthesis also reaches its highest level in the figure of 0,3%, accelerated. Therefore, it is possible to increase the yield on account of an extra feeding of greenhouse plants with CO₂.

We can decide the daily need of the greenhouse for carbon dioxide with the help of the following expression:

$$M_{CO_2} = 1,25 \cdot P \cdot \tau_p \cdot F_{gr} \quad (3)$$

where: P- an extra norm of feeding plants in the greenhouse with carbon dioxide, kg/m²hours; τ_p - the time of additional feeding plants with carbon dioxide during the sunny days of the day (in the process of photosynthesis), hours.

The daily need of the greenhouse for carbon dioxide with the help of the following expression P, greenhouse comparative size c_γ (depending on (the ratio of the greenhouse volume to its surface), it can be obtained as follows: $c_\gamma = 2,5$ - P=0,02 kg/(m²hours) $c_\gamma = 3,5$ - P=0,028 kg/(m²hours),

<https://cejsr.academicjournal.io>

$c_\gamma = 4,5$ - $P=0,036$ kg/(m²hours). For the applicable greenhouses in our conditions, it turns out that $c_\gamma \approx 4$ is $P=0,036$ kg/(m²hours).

We calculate the air exchange between the livestock building and the greenhouse. We determine the amount of carbon dioxide (CO₂) in the air exchange process. The amount of CO₂ $m=300$ kg divided by one cattle with an average weight of $c=106$ l/hours= $0,106$ m³/hours. Allowed CO₂ ingredients in the building for cattle $c_1=2$ l/m³.

The concentration of CO₂ in the composition of hot air is $c_2=3$ l/m³. By putting these values into the formula, we determine the hourly air flow rate (m³/hours).

$$L_{CO_2} = \frac{c \cdot n}{(c_2 - c_1)} = \frac{106 \cdot 40}{(3 - 2)} = 4240 \frac{m^3}{hours}, \quad (4)$$

where $c=106$ l/hours - the amount of CO₂, separated from one herd; n -the number of cattle.

During the performance of livestock buildings, harmful substances are constantly released into the atmosphere through the air. The exhaust of ventilation has nutrients for plants and is a secondary energy resource with a high energy potential, which, usually, irreplaceable, disappears, worsens the environmental situation when it spreads to the environment. Therefore, measures for the use of secondary energy resources in hothouses are considered necessary [14].

If we connect livestock buildings and greenhouses with modernized production technologies and technical means, it is possible to cut the output of harmful substances into the atmosphere as well as the unreasonable loss of heat energy.

(3) by equating the expression to (4) taking into account the density of the air, we decide the greatest area of the greenhouse in the feeding of plants with CO₂, separated from the cattle by the following formula:

$$F_{gr} = \frac{L_{CO_2} \cdot \rho \cdot \tau_{CO_2}}{1,25 \cdot P \cdot \tau_p} = \frac{c \cdot n \cdot \rho \cdot \tau_{CO_2}}{1,25 \cdot P \cdot \tau_p \cdot (c_2 \cdot c_1)}, m^2 \quad (5)$$

where: τ_{CO_2} - the time of decomposition of the amount of carbon dioxide from cattle, hours; ρ - air density, kg/m³; In calculations $\tau_{CO_2} = \tau_p = 10$ hours τ_{CO_2} can be considered.

Taking note of the above, we consider the area of the greenhouse when circulating the carbon dioxide air coming out of the building intended for the maintenance of 40 head cattle through the greenhouse as follows:

$$F_{gr} = \frac{0,106 \cdot 40 \cdot 1,97 \cdot 10}{1,25 \cdot 0,032 \cdot 10 \cdot (3 - 2)} \approx 209 m^2$$

Hence, taking into account the need for an average area of 6 m² for one head of livestock, the building area for 40 head of cattle is 240 m², while the carbon dioxide that separates from the cattle is a source of nutrients for plants in the greenhouse, and the area of 209 m² completely covers the need for carbon dioxide [4,7].

To cut the number of harmful gases contained in the air when creating a microclimate in ordinary livestock buildings, it is necessary to ventilate it with external air. As a result, a large amount of heat loss simultaneously leads to a deterioration of the environmental situation. We will have found solutions to these problems if we carry out this air exchange with a greenhouse built side by side with a livestock building.

We calculate the least area of the greenhouse, where the air temperature in the livestock building is $t_{lives.} = 26,8$ °C according to the figure when there is an air exchange through the greenhouse. First

<https://cejsr.academicjournal.io>

of all, we draw up the heat balance of the greenhouse:

$$Q_{gr.b} + Q_{inf} - Q_{rad} - Q_{ven} = 0 \quad (6)$$

where, $Q_{gr.b}$ - Heat lost through greenhouse barriers, W; Q_{inf} - Heat lost by infiltration, W; Q_{rad} - the heat that flows into the greenhouse through solar radiation, W; Q_{ven} - heat brought from the livestock building through ventilation, W.

The heat lost by infiltration, as it is seen in the literature, is equal to 10-11 % of the heat lost by the greenhouse barrier, usually, this lost heat can be written in the following form [7,12].

$$Q_{gr.b} + Q_{inf} = k \cdot F_{gr} \cdot (t_{gr} - t_{out}) \cdot K_b \cdot K_{inf} \quad (7)$$

where, k - it is the heat transfer coefficient of the greenhouse bed, which is equal to 5,8 for a two-layer film, W/(m²/°C); F_{gr} -greenhouse area, m²; K_b - it is a barrier coefficient, for greenhouses of semi-cylindrical shape $K_b = 1,4$; K_{inf} - become infiltration coefficient, $K_{inf} = 1,11$; t_{gr}, t_{out} - greenhouse and outdoor temperatures, respectively, °C.

We calculate the heat absorbed into the greenhouse by solar radiation by the following formula:

$$Q_{rad} = q_{rad} \cdot \alpha_n \cdot k_a \cdot F_{gr} \quad (8)$$

where, q_{rad} - average for the region, which is seen as solar radiation falling on the surface of the earth during the day $q_{rad} = 200 \text{ W/m}^2$ equal to; $\alpha_n \cdot k_a$ - the conduction and absorption coefficients of the greenhouse clear coating, respectively, can be obtained in calculations $\alpha_n \cdot k_a = 0,8$ [7,12,14].

(7), (8) putting expressions (6) into expression, we can write the heat balance of the greenhouse as follows:

$$k \cdot F_{gr} \cdot (t_{in} - t_{out}) \cdot K_b \cdot K_{inf} - q_{rad} \cdot \alpha_n \cdot k_a \cdot F_{gr} - L \cdot \rho \cdot c \cdot (t_{lives} - t_{gr}) = 0 \quad (9)$$

(9) from the expression we find the least area of the greenhouse according to the value found by the graph in figure $t_{out} = -6$ °C, the air temperature in the greenhouse, and the temperature in the livestock building $t_{in} = 18$ °C [3b]:

$$F_{grQ} = \frac{L \cdot \rho \cdot c \cdot (t_{lives} - t_{gr})}{k \cdot (t_{in} - t_{out}) \cdot K_b \cdot K_{inf} - q_{rad} \cdot \alpha_n \cdot k_a} \quad (10)$$

(10) we calculate the expression with attention to the above values:

$$F_{grQ} = \frac{1,18 \cdot 1,293 \cdot 1005 \cdot (26,8 - 18)}{5,8 \cdot (18 - (-6)) \cdot 1,4 \cdot 1,11 - 200 \cdot 0,8 \cdot 0,8} \approx 153 \text{ m}^2$$

This means that by utilizing the greenhouse from the free flow of heat separated from the livestock, as well as from the calculation of the Daily solar charge, the greenhouse with an average working area of 153 m² can fully compensate for the heat load. By calculating the average value of the surfaces found in the greenhouse from the calculation of carbon dioxide and the need for heat, we calculate the equal area of the greenhouse:

$$F_{gr.} = \frac{F_{grCO_2} + F_{gr.Q}}{2} = \frac{209 + 153}{2} = 181 \text{ m}^2 \approx 180 \text{ m}^2$$

4. Conclusion

In summary, if the working area of the building where 40 head cattle are stored is 240 m², if we place a greenhouse through a wall with the south side of this building, then by circulating the free heat and CO₂ gases separated from the cattle, we can fully give the greenhouse with a useful area of 180 m², taking into account that.

<https://cejsr.academicjournal.io>

The developed mathematical models of radiation-convective heat exchange of a two-block solar greenhouse with a underground heat accumulator, and water tank accumulator, as evidenced by a comparison of the calculation results using a mathematical model and field experimental data. The implemented modeling method and the obtained mathematical dependencies can be effectively used in new scientific research and for practical calculations.

On the basis of computational (theoretical) and experimental studies, methods of heat engineering and hydraulic calculations of tray heat storage systems greenhouse-livestock complex have been developed, which can be used in the calculations and design of solar greenhouses, in other areas of heat power engineering.

Reference

1. T A Faiziev and B M Toshmamatov 2021 Mathematical model of heat accumulation in the substrate and ground of a heliogreenhouse *IOP Conf. Series: Earth and Environmental Science*. 723 032006. doi:10.1088/1755-1315/723/3/032006.
2. Toshmamatov B, Davlonov Kh, Rakhmatov O, Toshboev A 2021 Recycling of municipal solid waste using solar energy *IOP Conf. Series: Materials Science and Engineering* 1030 012165. doi:10.1088/1757-899X/1030/1/012165
3. Aliyarova L A, Uzakov G N, Toshmamatov B M 2021 The efficiency of using a combined solar plant for the heat and humidity treatment of air *IOP Conf. Series: Earth and Environmental Science*. 723 052002. doi:10.1088/1755-1315/723/5/052002.
4. G N Uzakov, S M Shomuratova and B M Toshmamatov 2021 Study of a solar air heater with a heat exchanger – accumulator *IOP Conf. Series: Earth and Environmental Science*. 723 (2021) 052013. doi:10.1088/1755-1315/723/5/052013.
5. Khujakulov S.M., Uzakov G.N., Vardiyashvili A.B. Effectiveness of solar heating systems for the regeneration of adsorbents in recessed fruit and vegetable storages. //Applied Solar Energy. – USA. 2013. – vol.49, № 4. – pp. 257-260.
6. Uzakov G.N. Technical and economic calculation of combined heating and cooling systems vegetable store-solar greenhouse// Applied Solar Energy. – Allerton Press, USA, 2012. –vol.48, №1. –PP. 60-61.
7. Hayriddinov, B. E., N. S. Holmirzayev, and Sh H. Ergashev. "Combination of the solar greenhouse-livestock farms with the subsoil accumulator of heat.«." *Symbol of science». International scientific magazine. OMEGA SCIENCE INTERNATIONAL CENTER OF I,(OVATION)* 16 (2017).
8. Хайриддинов, Б.Э., Холмирзаев, Н.С., Халимов, Г.Г., Рысбаев, А.С. and Эргашев, Ш.Х., 2018. Муқобил энергия манбаларидан фойдаланиш. *Монография. Т. "ADAD PLYUS, 417*.
9. G.N. Uzakov. "Calculation of the heat engineering characteristics of a combined system of a vegetable storage facility and solar greenhouse". // Applied Solar Energy 47.3 (2011): 248-251.
10. Хайриддинов Б.Э., Холмирзаев Н.С., Эргашев Ш.Х., Хайриддинов А.Б., Нурматова Д.Ж. Комбинирование гелиотеплицы-живодноводческих ферм с подпочвенным аккумулятором теплица // Символ науки. 2017. №1. URL: <https://cyberleninka.ru/article/n/kombinirovanie-gelioteplicy-zhivodnovodchekih-ferm-s-podpochvennym-akkumulyatorom-teplitsa> (дата обращения: 06.10.2022).
11. G.N. Uzakov. "Efficiency of the use to energy of the biomass for autonomous power supply fruit-vegetable-vault". Europäische Fachhochschule ORT Publishing (2015): 92-94.

<https://cejsr.academicjournal.io>

12. Ergashev, Sh H., et al. "Results of mathematical modeling of nostatic temperature temperature heating of" livestock heat complex" through the use of solar and bio energy." *International Conference on Remote Sensing of the Earth: Geoinformatics, Cartography, Ecology, and Agriculture (RSE 2022)*. Vol. 12296. SPIE, 2022.
13. A A Khusenov et al 2022 IOP Conf. Ser.: Earth Environ. Sci. 1070 012032
14. Sh H Ergashev et al 2022 IOP Conf. Ser.: Earth Environ. Sci. 1070 012031
15. Khayriddinov B.E., Namazov F.A., Ergashev Sh.H. About mathematical of heliobioenergetic circuit for heating system of stock and poultry buildings. «Razvitiye energosistem APK: perspektivniye texnologii» materiali mejdunarodnoy nauchno-prakticheskoy konferensii Instituta agoroinjenerii, Chelyabinsk, 2018. p.p 101-107.
16. Ergashev Sh.X., Xayriddinov B.E. Issledovaniye teploperedachi podpochvennogo akkumulyatora tepla geliobioenergeticheskoy otopitelnoy sistemi gelioteplitsa-jivotnovodcheskiye pomesheniya. Nauka, texnika i obrazovaniye. Nauchno-metodicheskij jurnal. Moskva 2019. №11(64) . s. 34-41.
17. Файзиев Т.А., Эргашев Ш.Х., Рўзикулов. Ф.Ю., and Рўзикулов. Ф.Ю.. "ЧОРВАЧИЛИК КОМПЛЕКСЛАРИНИ ЛОЙИҲАЛАШ ВА УЛАРНИНГ ИССИҚЛИК ҲАМДА НАМЛИК РЕЖИМЛАРИ ҲИСОБИ" Инновацион технологиялар , no. 2 (42), 2021, pp. 62-67.
18. Khayriddinov Botir Egamberdiyevich, Ergashev Shakhriyor Khamudillayevich. Accumulation of heat in the substrate-soil cover around the heat accumulator of heliogreenhouse-livestock building. *The american journal of engineering and technology*. JULY 2020. Page No.: 30-34. Volume-II Issue-VII.
19. Ergashev Sh.X., Xayriddinov B.E. Matematicheskoye modelirovaniye i teploobmennix protsessov v podpochvennom akkumulyatorom tepla v pomesheniyax jivotnovodcheskix i ptitsevodcheskix ferm. Monografia pokonferencyjna "Science, research, development #13" Technics and technology. Berlin – 30.01.2019-31.01.2019. pp. 191-199.
20. Xayriddinov B.E., Xolmirzayev N.S., Ergashev Sh.X., Nurmatova D.J., Otamurodov R.G. Matematicheskaya model geliobioenergeticheskogo kontura dlya sistemi otopleniya jivotnovodcheskix pomeshenii. *Mejdunarodniy nauchniy jurnal Molodoy uchyoniy* №24 (158)/2017. S. 209-212.